

Polished Weld Elbows

Sanitary Fittings

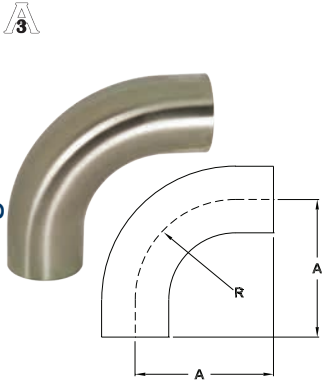

90° with Tangents - B2S

Tube OD	Dimensions		Wall Thickness	Polished ID/OD	Polished ID/OD
	A	R		304 Stainless Steel Part #	316L Stainless Steel Part #
½"	3.000"	1.125"	.065"	---	B2S-R50P
¾"	3.000"	1.125"	.065"	---	B2S-R75P
1"	2.062"	1.500"	.065"	B2S-G100P	B2S-R100P
1½"	2.937"	2.250"	.065"	B2S-G150P	B2S-R150P
2"	4.062"	3.000"	.065"	B2S-G200P	B2S-R200P
2½"	5.187"	3.750"	.065"	B2S-G250P	B2S-R250P
3"	6.312"	4.500"	.065"	B2S-G300P	B2S-R300P
4"	8.312"	6.000"	.083"	B2S-G400P	B2S-R400P

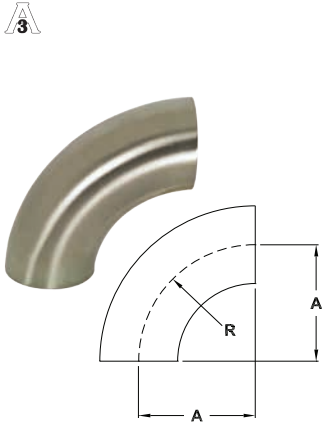

90° - B2WCL

Tube OD	Dimensions		Wall Thickness	Polished ID/OD	Polished ID/OD
	A	R		304 Stainless Steel Part #	316L Stainless Steel Part #
½"	1.125"	1.125"	.065"	---	B2WCL-R50P
¾"	1.125"	1.125"	.065"	---	B2WCL-R75P
1"	1.500"	1.500"	.065"	B2WCL-G100P	B2WCL-R100P
1½"	2.250"	2.250"	.065"	B2WCL-G150P	B2WCL-R150P
2"	3.000"	3.000"	.065"	B2WCL-G200P	B2WCL-R200P
2½"	3.750"	3.750"	.065"	B2WCL-G250P	B2WCL-R250P
3"	4.500"	4.500"	.065"	B2WCL-G300P	B2WCL-R300P
4"	6.000"	6.000"	.083"	B2WCL-G400P	B2WCL-R400P
6"	9.000"	9.000"	.109"	B2WCL-G600P	B2WCL-R600P
8"	12.000"	12.000"	.109"	B2WCL-G800P	B2WCL-R800P

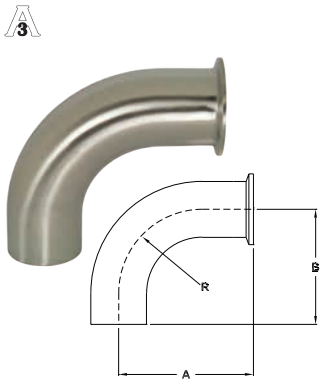

90° Clamp x Weld - B2CM

Tube OD	Dimensions			Wall Thickness	Polished ID/OD	Polished ID/OD
	A	B	R		304 Stainless Steel Part #	316L Stainless Steel Part #
1"	2.562"	2.062"	1.500"	.065"	B2CM-G100	B2CM-R100
1½"	3.438"	2.937"	2.250"	.065"	B2CM-G150	B2CM-R150
2"	4.562"	4.062"	3.000"	.065"	B2CM-G200	B2CM-R200
2½"	5.688"	5.187"	3.750"	.065"	B2CM-G250	B2CM-R250
3"	6.812"	6.312"	4.500"	.065"	B2CM-G300	B2CM-R300
4"	8.937"	8.312"	6.000"	.083"	B2CM-G400	B2CM-R400

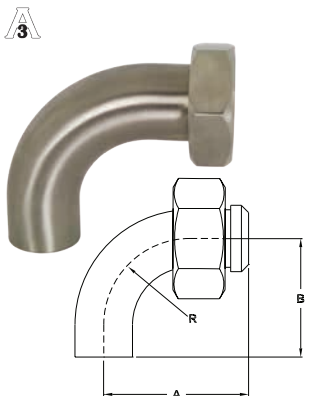

90° Plain Bevel Seat with Hex Nut x Weld - B2FP

Tube OD	Dimensions			Wall Thickness	Polished ID/OD
	A	B	R		304 Stainless Steel Part #
1½"	3.656"	2.937"	2.250"	.065"	B2FP-G150
2"	4.812"	4.062"	3.000"	.065"	B2FP-G200
2½"	6.062"	5.187"	3.750"	.065"	B2FP-G250
3"	7.218"	6.312"	4.500"	.065"	B2FP-G300